

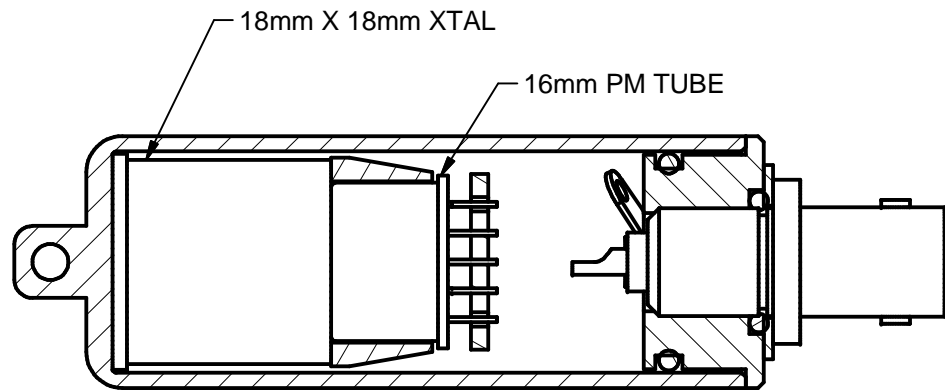

REVISION HISTORY			
REV	DESCRIPTION	DATE	BY
1	VALID	9/3/2010	CMC

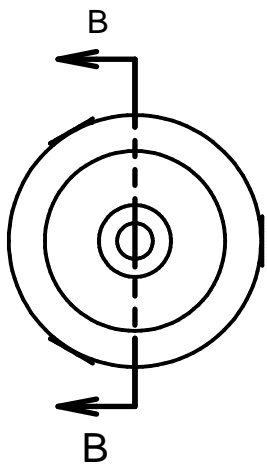

SECTION B-B
SCALE 1.5 : 1

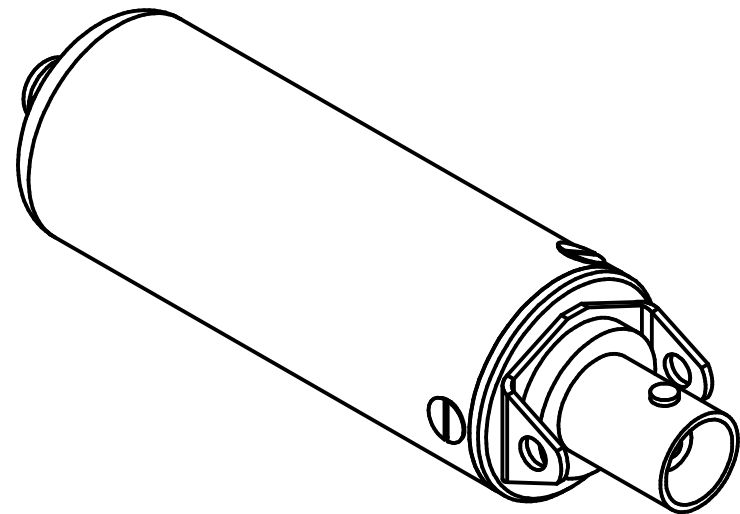
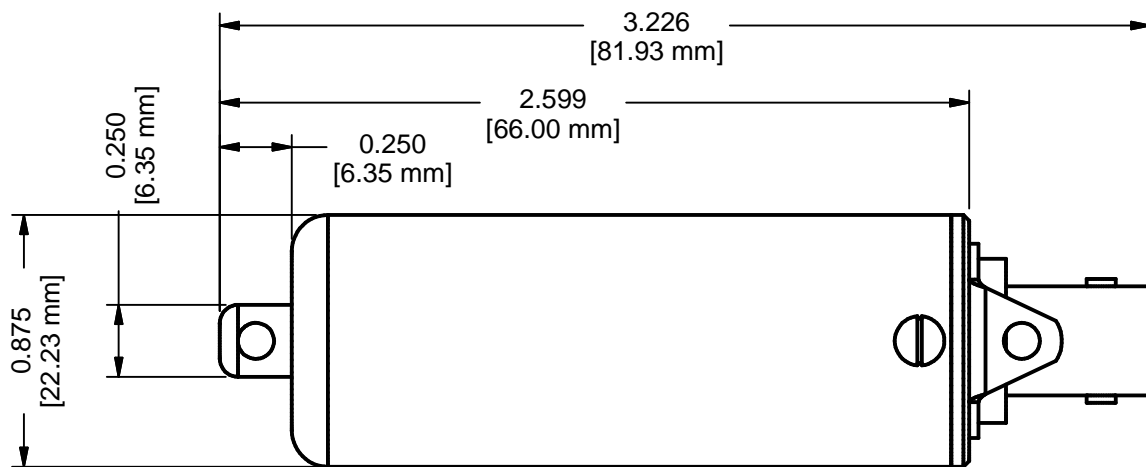

DWN	DATE	CHK	DATE	APP	DATE
CMC	9/3/2010				
DWG NUM: 4002-1070				SCALE: 1.5	
TITLE M 44-159-1 CsI DETECTOR					
 LUDLUM MEASUREMENTS, INC. 501 OAK STREET SWEETWATER, TEXAS 79556		SERIES 2		SHEET 1070	

REVISION HISTORY			
REV	DESCRIPTION	DATE	BY
1	VALID	9/3/2010	CMC

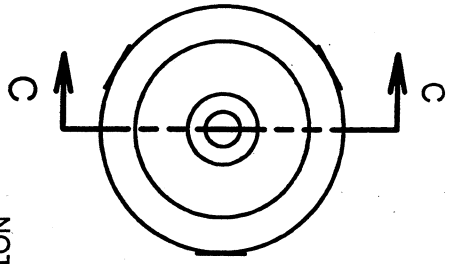

NOTES:

1. WRAP SIDE AND ONE END OF XTAL WITH TEFLON TAPE.
2. OPTICALLY COUPLE PMT TO XTAL AND WRAP WITH BLACK TAPE.
3. WRAP WITH SPONGE, CONNECT WIRES TO BOARD, AND INSERT INTO BODY.

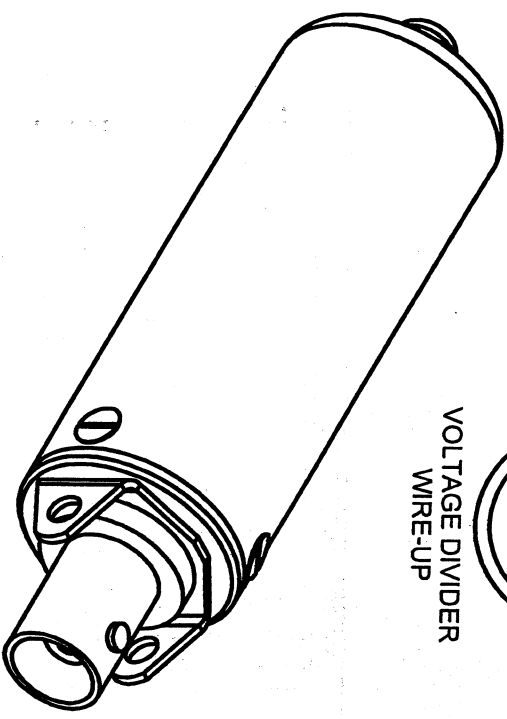
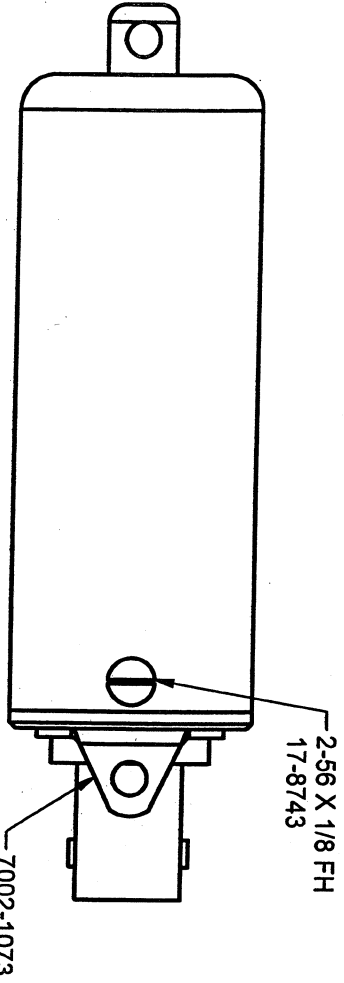
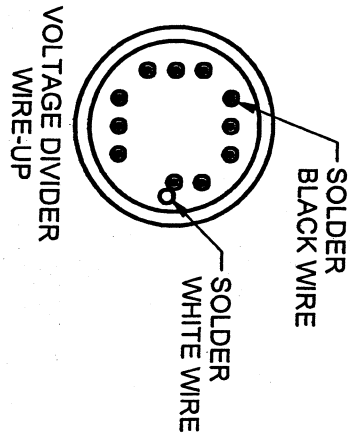
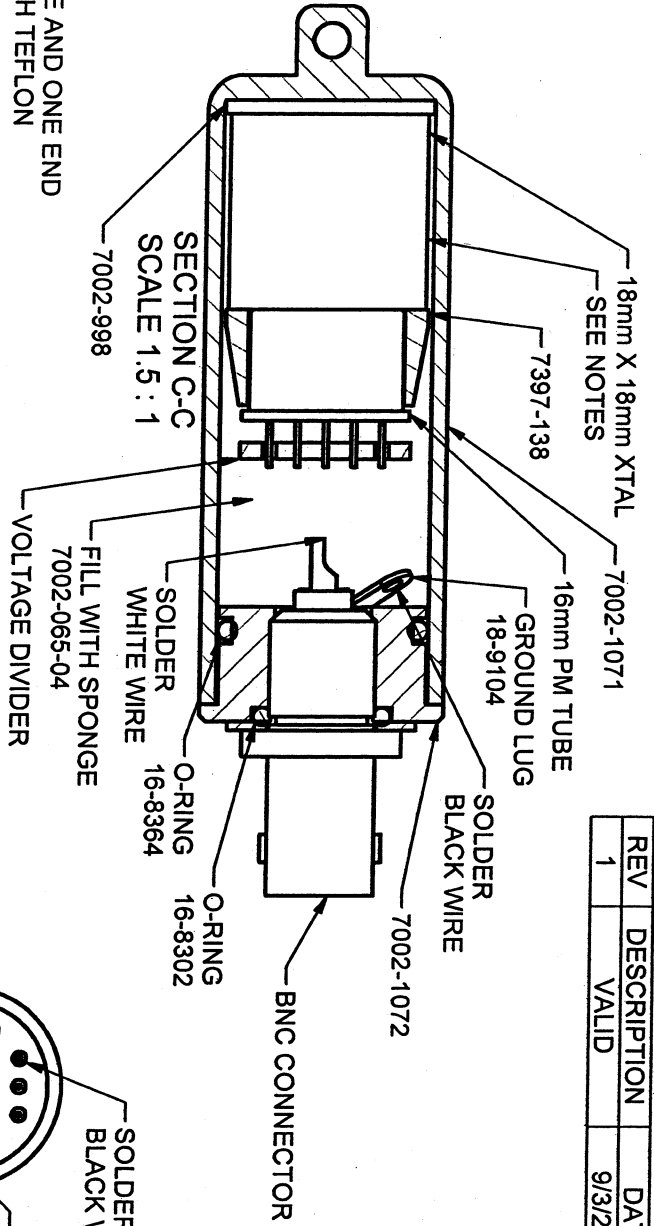

DWN	DATE	CHK	DATE	REV	DATE
CMC	9/3/2010			1	9.3.2010
DWG NUM: 4002-1070					
TITLE: M 44-159-1 ASSEMBLY					
SCALE: 1.5					
LUDLUM MEASUREMENTS, INC.					
801 OAK STREET					
SHERMANTON, TEXAS 76589					
SERIES				SHEET	
2				1070A	